

110

Electric

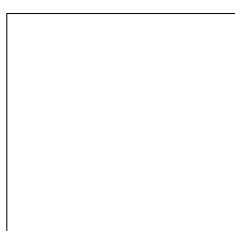

Users Guide

Installation & Service Instructions

U102210 - 04



www.rangemaster.co.uk

Be safe

Warning

Accessible parts will become hot in use. To avoid burns and scalds children should be kept away.

If the younger members of your family are allowed into the kitchen we strongly advise that they are kept under supervision at all times.

We recommend you read the 'General Safety Instructions' section if you have not used a electric cooker before. We describe some basic guidelines on how to use a cooker safely.

Electricity on

Make sure that the electricity supply is turned on.

Peculiar smells

When you first use your cooker it may give off a slight odour. This should stop after a little use.

Contents

The Hob	Page 4
The Griddle	Page 4
The Warmer	Page 5
The Grill	Page 6
The Ovens	Page 7
The Clock	Page 8
Cooking using the timer	Page 9
Oven cooking	Page 10
Oven shelves	Page 10
The Handyrack	Page 11
Oven light	Page 11
The Browning Element	Page 11
Storage	Page 11
Oven cooking guide	Page 12
Cleaning your cooker	Page 14
Moving your cooker	Page 16
Troubleshooting	Page 17
General Safety Instructions	Page 19
Installation	Page 21
Circuit Diagram	Page 25
Technical Data	Page 26

The Hob

1

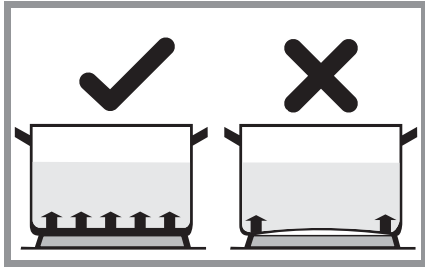

Always place the pan on the hobplate before switching on.

Use correct pans with thick flat bottoms. For efficient heat transfer and even heat distribution a perfectly flat base pan is essential.

These will make total contact with the whole surface of the hobplate, give maximum efficiency and avoid damage to the hobplate.

2

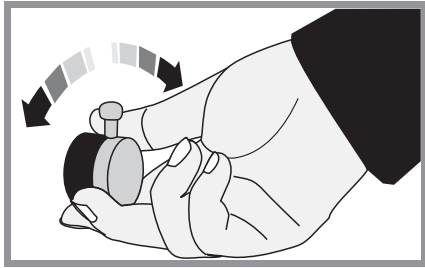

The drawing by each knob indicates which hob plate that knob controls.

The hobplates have 6 heat settings and the control knobs can be turned either clockwise or anticlockwise.

The kind of pan you use and the quantity of food affects the setting required. Higher settings are required for larger quantities of food.

- 1 - 2..... Delicate dishes (e.g. melting butter)
 - 3 - 4..... Steaming and simmering (e.g. vegetables)
 - 5 - 6..... Boiling and frying (e.g. vegetables, pancakes)
-

3

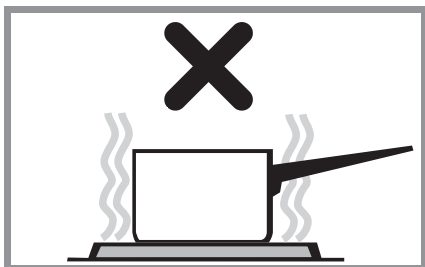

Pans must be large enough to cover the hobplate completely. Never use a pan smaller than the hobplate. The pan base must absorb all the heat from the hobplates and thereby protect it from overheating. Where possible always use a lid on the saucepan.

4

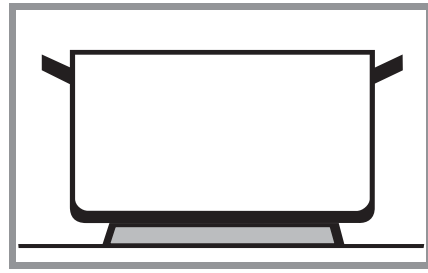

If you use a pan bigger than the hob plate you will need to lift off the pan support around that plate.

Care of the Hobplates

The hobplates are made of cast iron, which will rust if left wet.

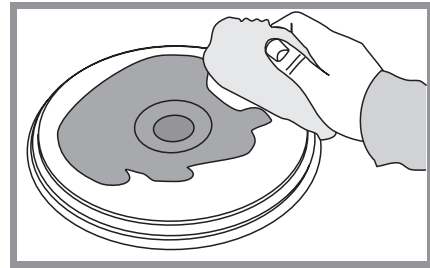

Don't put wet pans on the hobplates. If liquid is accidentally spilt on the hobplate clean with a damp cloth, then switch to the lowest setting to dry the appropriate hobplate.

Oil the hobplates sparingly about once a month (dependant on use) with a few drops of cooking oil then rub over with a cotton cloth. Take care NOT to oil the outer stainless bezel or the red discs on any of the hobplates.

NB The red disc is an identifying mark for high speed hobplates. It may wear away with use but this will not affect hob performance in any way..

The Griddle

1

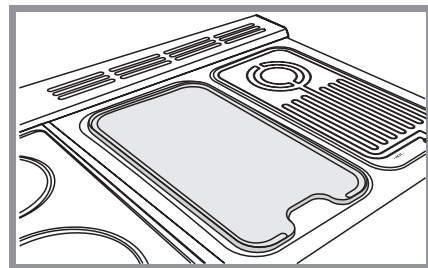

The griddle is designed for cooking food on directly.

2

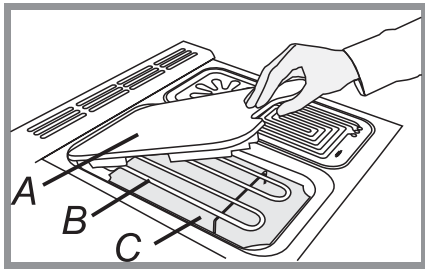

A griddle, B element, C reflector

Before turning on always check that the reflector is in position below the griddle plate.

3

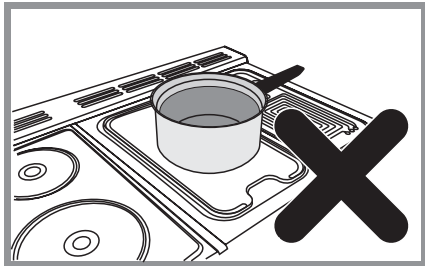

Don't use pans of any kind on the griddle. The top surface of the griddle has been coated with a special non-stick finish to make it easier to clean. To protect the coating always use heat resistant plastic, wooden or nylon utensils, avoid using metal cooking utensils as they may scratch and damage the non-stick coating.

4

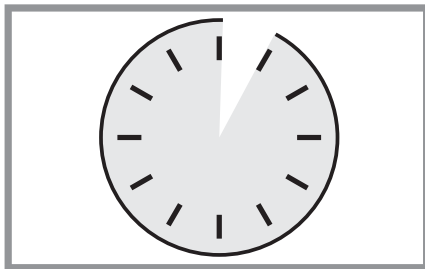

Preheat the griddle for a maximum of 5 minutes before adding food. Leaving it longer may cause damage. The controls can be turned to a lower position simply by turning the control knob to a lower number.

5

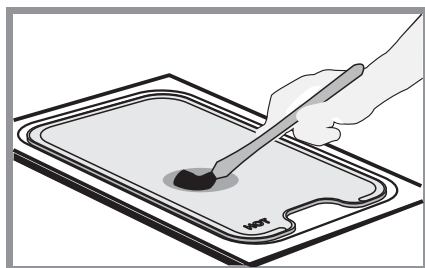

Brush the griddle with oil (if required) before adding the food. To reduce the heat, turn the control to a lower number. Personal experience will soon familiarise you with the correct setting to use for cooking.

As a guide refer to the cooking chart below. After cooking allow the griddle to cool before cleaning.



Use the following heat settings as a guide for griddle cooking. Preheat for 5 minutes before cooking.

Type of Food	Heat Setting
Bacon	6 - 3
Chops	6 - 3
Steak	6 - 3
Burgers	6 - 3
Fish Cakes	3 - 1

Experience will soon familiarise you with the correct setting to use for cooking.

After cooking allow the griddle to cool before cleaning.

The Warmer

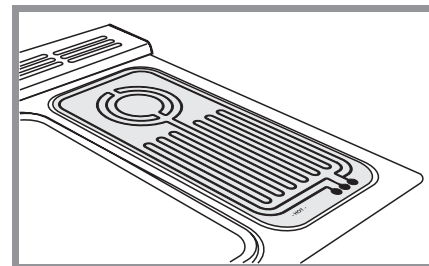

The Warmer can be used for keeping food warm while the final touches are put to a meal. For best results preheat a covered serving dish for 10 minutes on the Warmer before adding the food.

Turn the control knob clockwise to the 'On' position. The 'HOT' indication light glows on the Warmer.

CAUTION:- If a crack in the Warmer surface becomes visible, due to accidental damage etc., isolate the appliance from the electricity supply immediately by turning it off at the wall and arrange for its repair.

DO NOT RECONNECT THE COOKER TO THE ELECTRICITY SUPPLY UNTIL AFTER REPAIR!

The Grill

CAUTION: Accessible parts may be hot when the grill is in use. Young children should be kept away.

1

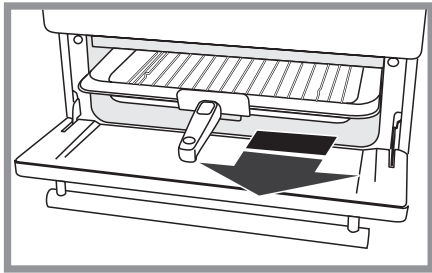

Remove the pan from the bottom of the grill compartment.

2

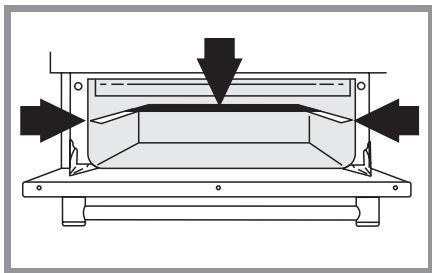

After placing your food on the grill tray pan, slide the grill pan onto the side supports just below the elements. Make sure it is pushed right in and touches the backstop.

3

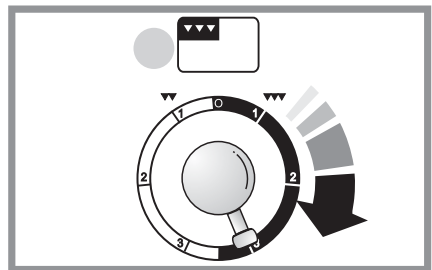

The grill has two elements that allow either the whole area of the pan to be heated or only the right hand half of the grill pan to be heated.

Turn the control knob clockwise to heat the whole grill - turn it the other way to just heat the right hand half.

4

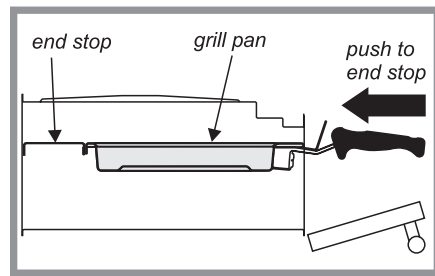

For best results preheat for 2 minutes with the grill pan in position. After placing your food on the grill pan grid, slide the grill pan onto the side supports.

Make sure it is pushed right in and touches the back stop.

Never close the grill door when the grill is on.

5

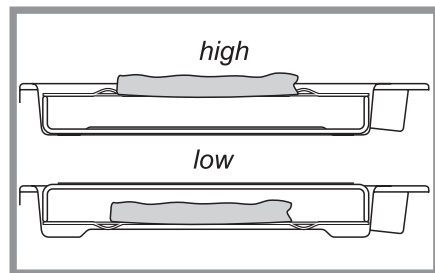

The grill pan grid can be turned over to give two grilling positions.

Never close the grill door while the grill is on.

Before using for the first time, run the grill full for 15 minutes (with the grill pan in position) to dispel manufacturing odours. Open a window to clear the smell.

Don't leave the grill on for more than a few moments, without the grill pan underneath it.

The grill trivet can be removed and the food placed on it while you are waiting for the grill to preheat.

You can brown the top of dishes cooked in the oven, under the grill by placing the dish onto the base of the grill pan which can easily slide along the floor of the grill compartment.

The Ovens

During use the appliance becomes hot. Care should be taken to avoid the touching heating elements inside the oven.

The clock must be set to the time of day before the ovens will work. See 'The Clock' section for instructions on setting the time of day

Before using for the first time, heat the ovens to 200°C for 30 minutes to dispel manufacturing odours. Open a window to clear the smell..

1

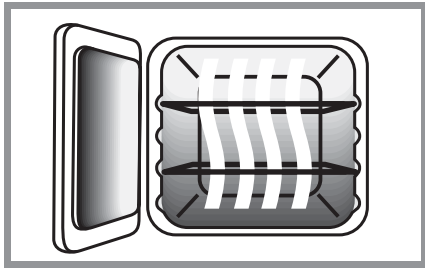

The Left hand Oven

The left hand conventional oven is fitted with two heating elements, one visible in the top of the oven and the second under the oven base.

Be careful to avoid touching the top element and element deflector when placing or removing items from the oven.

2

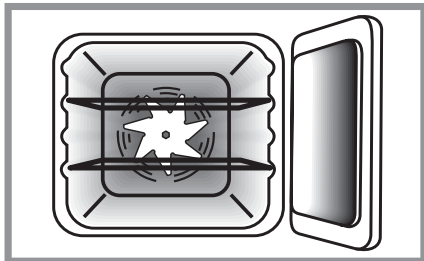

The Right hand Fan Oven

The fan in the right hand oven circulates hot air continuously which means faster more even cooking.

The recommended cooking temperatures for a fanned oven are generally lower than a non-fanned oven.

3

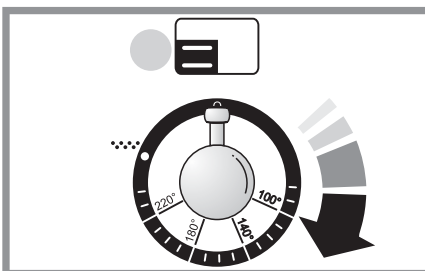

Turn the oven knob to the temperature you need.

4

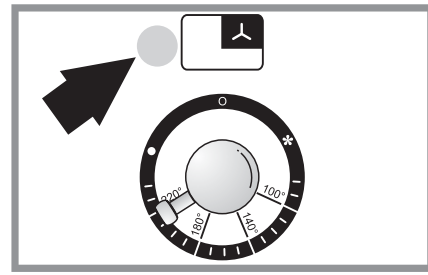

The oven indicator light will glow until the oven has reached the temperature you selected. It will then cycle on and off during cooking.

5

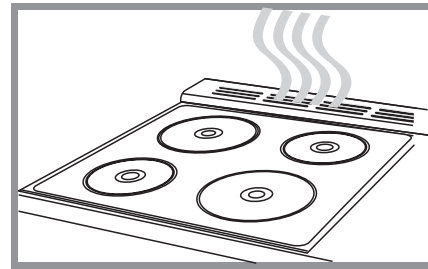

During cooking, food naturally produces steam, particularly when cooking foods with high water content (e.g. oven chips). There may be some steam visible at the grille at the rear of the hotplate and the bottom of the left hand door. This is perfectly normal. Steam can condense to water droplets on the cool outer trim or the oven door. It may be necessary during cooking to wipe away any moisture with a soft cloth. This will also help to prevent soiling and discolouration of the oven exterior by cooking vapours.

Take care when opening the oven door as there may be a momentary puff of steam when the oven door is opened. Stand well back and allow any steam to disperse.

6

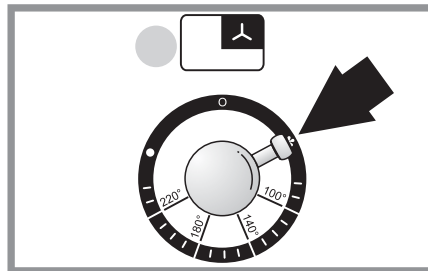

* The fan only setting. The fan circulates air inside the oven but the heating element is not turned on. This setting is useful for defrosting frozen foods. Whole chickens and large joints of meat should be defrosted in the refrigerator. Do not defrost in a warm oven or whilst the adjoining oven is hot.

The Clock

You can use the timer to turn the ovens on and off. The clock must be set to the time of day before the ovens will work.

To set the time of day

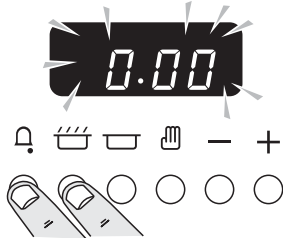

Press and hold as above. At the same time, press (-) or (+) until the correct time shows. Don't forget it's a 24 hour clock. If you make a mistake or press the wrong button, turn off the power supply for a minute or two and start again.

To time something that's cooking (minute minder)

<p>Press and hold the Minute Minder (🔔).</p>	
--	--

<p>At the same time press (-) or (+) until the time you want to cook for is shown.</p>	
--	--

You can check time remaining by pressing 🔔 and cancel the beeper by pressing 🔔.

To stop automatically

Use when you have started the oven manually.

<p>Press and hold the Stop Time (🔒) button.</p>	
---	--

At the same time press (-) or (+) until your required 'Stop Time' shows. AUTO will show in the display. When your cooking is finished the beeper sounds. TURN THE OVEN KNOB TO 0 FIRST, then press 🔔 once to stop the beep, press 🔔 again to return to manual cooking.

To start and stop the oven automatically

Before you set the clock, you must have two numbers clearly in mind.

The 'cook period', which is the period of time you want the oven to cook.

The 'stop time', which is the time of day you want the oven to stop cooking.

You cannot set a start time directly - this is set automatically by setting the cooking period and stop time.

<p>Press and hold the Cook Time (🔥) button. At the same time press (-) or (+) until your required 'cook period' shows.</p>	
--	--

<p>Press and hold the Stop Time (🔒) button. At the same time press (-) or (+) until your required 'stop time' shows. AUTO will show in the display.</p>	
---	--

Set the oven to the required temperature. When your cooking is finished the beeper sounds. TURN THE OVEN KNOB TO 0 FIRST, then press 🔔 once to stop the beep, press 🔔 again to return to manual cooking.

If you are out, don't worry about the beeper going off, it stops after a while. When you return, TURN THE OVEN KNOB TO 0 FIRST, then press 🔔 twice, to return to manual cooking.

AUTO is showing, you want to reset to manual cooking.

When cancelling an automatic setting, any cooking time already set must be returned to 0.00 before you can return to manual, by pressing the 🔔 button.

Clock Special Features

Key Lock

When the key lock is activated, the clock can be operated as usual but the oven is locked and will not come on. This means that your child could select a cook program but the program will not be activated and oven will not be switched on.

To activate the key lock

Make sure that the clock is in manual mode and cancel any active programs.

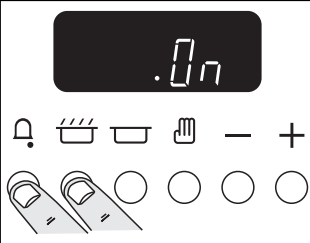
Hold the Minute Minder (🔔) and Cooktime (🍲) buttons for about 8 seconds. 'On' will appear on the display.	
---	---

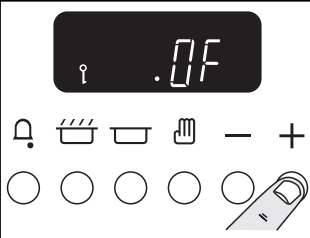
Press the '+' button once. 'Of' will appear on the display.	
---	---

The clock oven control functions are now locked. After a few seconds the display will revert to show the time of day and the key symbol (🔔).	
--	--

To turn off the key lock

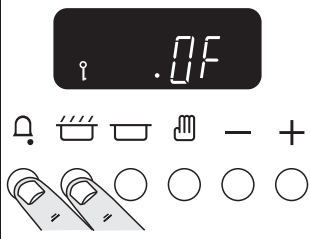
Hold the Minute Minder (🔔) and Cooktime (🍲) buttons for about 8 seconds. 'Of' will appear on the display.	
---	---

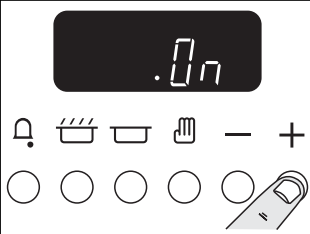
Press the '+' button once. 'On' will appear on the display.	
---	---

After a few seconds the display will revert to show the time of day.

The oven and the clock oven control functions can now be used normally.

Cooking using the timer

The timer can be used to turn just one oven or both on and off automatically. The start and stop time must be the same for both ovens but different cooking temperatures can be set.

If you want to turn one of the ovens on at the same time as the timer is set for automatic cooking, you must wait until the timer has turned on the oven/ ovens first. Then you can adjust either of them manually in the normal way.

You can set the oven to turn on any time over the following 24 hour period

If you want to cook more than one dish, choose dishes that require approximately the same time. However, dishes can be 'slowed down' slightly by using small containers and covering them with aluminium foil, or 'speeded up' slightly by cooking smaller quantities or placing in larger containers.

Very perishable foods such as pork or fish should be avoided if a long delay period is planned, especially in hot weather.

*Don't place warm food in the oven.
Don't use an oven already warm.
Don't use if an adjoining oven is warm.*

Avoid using wine or beer if there is a delay period, as fermentation may take place.

To avoid curdling, cream should be added to dishes just before serving.

Fresh vegetables, which may discolour during a delay period, should be coated in melted fat or immersed in a water and lemon juice solution.

Many frozen foods are ideal for delayed cooking and can be placed in the oven while still frozen.

Fruit pies, custard tarts or similar wet mixtures on top of uncooked pastry are only satisfactory if there is a short delay period. Dishes containing leftover cooked meat or poultry should not be cooked automatically if there is a delay period.

*Whole poultry must be thoroughly defrosted before placing in the oven.
Check that meat and poultry are fully cooked before serving.*

Oven cooking

The wire shelves should always be pushed firmly to the back of the oven.

Baking trays meat tins etcetera should be placed level centrally on the oven's wire shelves. Keep all trays and containers away from the sides of the oven, as overbrowning of the food may occur.

For even browning, the maximum recommended size for a baking tray is 320mm (12 1/2") by 305mm (12").

Cooking high moisture content foods can create a 'steam burst', when the oven door is opened. When opening the oven stand well back and allow any steam to disperse.

When the oven is on, don't leave the door open for longer than necessary, otherwise the knobs may get very hot.



- Always leave a 'fingers width' between dishes on the same shelf. This allows the heat to circulate freely around them.
- The Cook & Clean oven liners (see *Cleaning your cooker*) work better when fat splashes are avoided. Cover meat when cooking.



- To reduce fat splashing when you add vegetables to hot fat around a roast, dry them thoroughly or brush lightly with cooking oil.
- Sufficient heat rises out of the oven while cooking to warm plates in the grill compartment.
- If you want to brown the base of a pastry dish, preheat a baking tray for 15 minutes before placing the dish in the centre of the tray.
- Where dishes may boil and spill over during cooking, place them on a baking tray.

Oven shelves

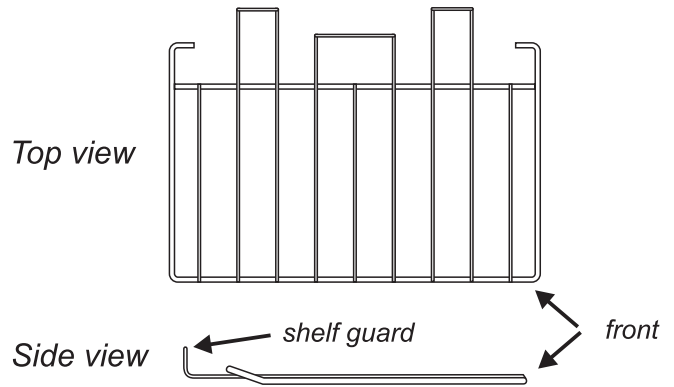

the shelf guard should be at the back pointing upwards
As well as the flat shelves some models are supplied with a drop shelf. The drop shelf increases the possibilities for oven shelf spacing.

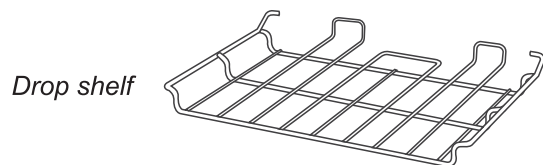
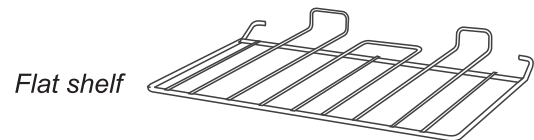

The oven shelves can be easily removed and refitted.

Pull the shelf forward until the back of the shelf is stopped by the shelf stop bumps in the oven sides.

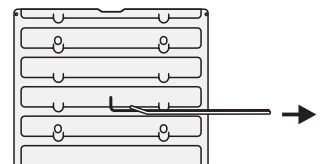

Lift up the front of the shelf so the back of the shelf will pass under the shelf stop and then pull the shelf forward.

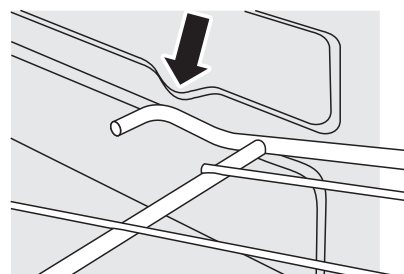
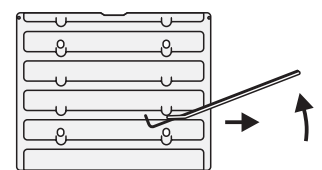

To refit the shelf, line up the shelf with a groove in the oven side and push the shelf back until the ends hit the shelf stop. Lift up the front so the shelf ends clear the shelf stops, and then lower the front so that the shelf is level and push it fully back.

The Handyrack

The maximum weight that can be held by the Handyrack is 5.5kg (12lb). It should only be used with the supplied meat tin, which is designed to fit the Handyrack. Any other vessel could be unstable.

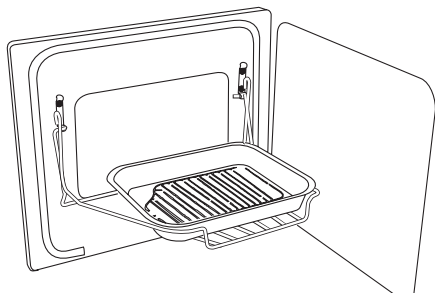

The Handyrack fits to the left hand oven door only. Food cooking on it is easy to attend to, because it's accessible when the door is open. It can be fitted at two different heights. One of the oven shelves must be removed and the other positioned to suit.

When the Handyrack is used in its highest position, other dishes can be cooked on the bottom shelf position of the oven or standing on the base of the oven

When the Handyrack is used in its lowest position, other dishes can be cooked on the second shelf position of the oven or standing on the base of the oven.

To fit the Handyrack, locate one side of it on the door bracket.

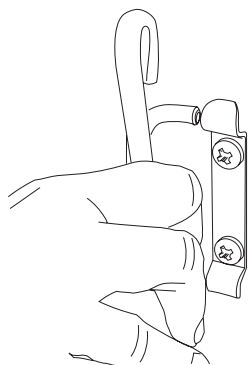
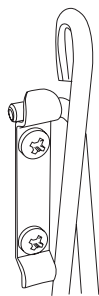

Then spring the other side out to clip it onto the other bracket.

Oven light



Press the appropriate button to turn on one of the oven lights.

If one of the oven lights fail, *turn off the power supply* before you change the bulb. See the 'Troubleshooting' section for details on how to change an oven light bulb.

The Browning Element

The Browning Element is positioned in the top of the left hand oven. It can be used at the end of a normal cooking period to give extra browning to au gratin dishes or give a crisper finish to meat.

After the normal cooking is finished turn the left hand oven thermostat knob clockwise to the browning position, indicated by (•••••) on the fascia panel.

Only the browning element will operate when the thermostat is turned to this position. The top and base cooking elements will automatically switch off.

Storage

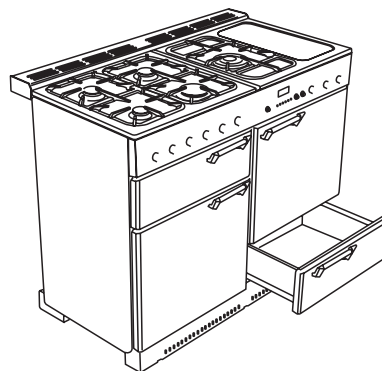

The bottom drawer is for storing oven trays and other cooking utensils. It can get very warm, don't store anything in it that may melt or catch fire. The drawer can be removed completely by pulling it right out and up..

Oven cooking guide

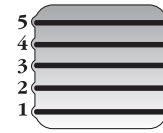

Food	LH Convection Oven		RH Fan Oven	
	Temperature	Shelf Position	Temperature	Approximate Cooking Time
FISH				
	190°C	3	180°C	Fillets 15-20mins.
	190°C	3	180°C	Whole 10mins.per 500g + 10mins.
	190°C	3	180°C	Steaks according to thickness.
ROAST MEATS				
Beef with bone	160°C	2-3	150°C	20-25mins. per 500g + 20-25mins.
	200°C	2-3	190°C	15-20mins. per 500g + 15-20mins.
Beef without bone	160°C	2-3	150°C	30-35mins. per 500g + 30-35mins.
	200°C	2-3	190°C	20-25mins. per 500g + 20-25mins.
Lamb	160°C	2-3	170°C	30-35mins. per 500g + 30-35mins.
	200°C	2-3	190°C	25-35mins. per 500g + 25-30mins.
Pork	160°C	2-3	150°C	35-40mins. per 500g + 35-40mins.
	200°C	2-3	190°C	25-30mins. per 500g + 25-30mins.
Stuffed and rolled - Add approx. 10 mins. per 500g to above cooking times or cook at 200°C for 20mins. then 160°C for remainder.				
THOROUGHLY THAW FROZEN JOINTS AND POULTRY BEFORE COOKING.				
POULTRY				
Chicken	160°C	2-3	150°C	20-25mins. per 500g + 20-25mins.
	200°C	2-3	190°C	15-20mins. per 500g + 15-20mins.
Turkey	160°C	2	150°C	20-25mins. per 500g + 20-25mins.
	200°C	2	190°C	15-20mins. per 500g + 15-20mins.
Stuffed Poultry - Cook at 200°C or at 200°C for 20mins. then 160°C for remainder. Prepacked (fresh or frozen) follow packers cooking times				
CASSEROLE	140-150°C	2-3	140°C	2-4hrs according to recipe
YORKSHIRE PUDDING	220°C	4	200°C	Large tin 30-35mins. Individual 10-20mins.
CAKES				
Very Rich Fruit	140°C	2	140°C	45-50mins. per 500g mixture
Rich fruit (180mm)	150°C	2	145°C	2½-3hrs.
Madeira (180mm)	160°C	2	150°C	80-90mins.
Queen Cakes	190°C	3 & 5 or 3	180°C	15-25mins.
Scones	220°C	2 & 4 or 3	210°C	10-15mins.
Victoria Sandwich	180°C	2 & 4 or 3	170°C	20-30mins.
PASTRIES				
Plate Tart	200°C	2 & 4	190°C	45-50mins. Interchange after 25mins.
Fruit Pie	200°C	2 & 4	190°C	35-40mins.
Tartlets	200°C	4	190°C	15-20mins. according to size.
Puff Pastry	220°C	2,3 or 4	200°C	20-40mins. according to size.
BREAD	220°C	2 & 4	200°C	20-30mins.
MERINGUES	110°C	3	100°C	2-2½hrs
PUDDINGS				
Baked Egg Custard	160°C	3	150°C	45mins.-1hr.
Baked sponge pudding	190°C	3	180°C	40-45mins.
Milk pudding	140-150°C	3	150°C	2-3hrs.

500g is approximately 1lb (1lb 2oz)

The oven control settings and cooking times given in the table opposite are intended to be used only as a guide. Individual tastes may require the temperature to be altered to provide a preferred result.

When baking in the right hand fanned oven, use the minimum cooking time shown in the table. Food is cooked at lower temperature in a fan oven than in a conventional oven. When using recipes, reduce the temperature by 10°C and the cooking time by 5-10 minutes. The temperature in the fanned oven does not vary with height in the oven - so you can use any shelf.

Always leave at least one runner space between shelves when 2 tier cooking. Place baking trays, individual cake tins or baking dishes centrally on the oven shelf. For best results pre-heat the oven until the oven indicator light goes out.

Cleaning your cooker

Essential information

Before thorough cleaning isolate the electricity supply. Remember to switch on the electricity supply before use.

Never use paint solvents, washing soda, caustic cleaners, biological powders, bleach, chlorine based bleach cleaners, coarse abrasives or salt. Don't mix different cleaning products - they may react together with hazardous results. Recommended cleaning materials are shown in the table at the end of this section.

If you want to move your cooker for cleaning, see the section called 'Moving your cooker'.

All parts of the cooker can be cleaned with hot soapy water - **but take care that no surplus water seeps into the appliance.**

For cleaning materials see the 'Cleaning Table' opposite.

Hob

If spillage does occur on the hobplates wipe with a damp cloth then heat up at the lowest setting until dry. Keep the plates dry and free from moisture to avoid rust spots.

The Hob Top

Use only a moist slightly soapy cloth and dry with a soft clean cloth.

DO NOT USE ANY ABRASIVES.

Griddle

Always clean the griddle after use. Allow to cool completely before removing. Immerse the griddle plate in hot soapy water. Use a soft cloth or, for stubborn stains, a nylon washing up brush.

NEVER USE CAUSTIC OR ABRASIVE CLEANERS AS THESE WILL DAMAGE THE SURFACE.

The element under the griddle is hinged and can be lifted upwards at the front to make removal of the reflector easier.

Note:-

ALWAYS REPLACE THE REFLECTOR BEFORE USING THE GRIDDLE.

Control Panel and Doors

The control panel and control knobs should only be cleaned with a soft cloth wrung out in clean hot soapy water - **but take care that no surplus water seeps into the appliance.** Wipe with a clean dampened cloth then polish with a dry cloth. The oven doors should only be cleaned with a soft cloth wrung out in clean hot soapy water.

Grill

The grill pan and grid should be washed in hot soapy water. After grilling meats or any foods that soil, leave to soak for a few minutes in the sink immediately after use. Stubborn particles may be removed from the grid by using a nylon brush.

The Ovens

The ovens have panels which have been coated with a special enamel that partly cleans itself. This does not stop all marks on the lining, but helps to reduce the amount of manual cleaning needed.

The Cook & Clean panels work better above 200°C. If you do most of your cooking below this temperature, occasionally remove the panels and wipe with a lint free cloth and hot soapy water. The panels should then be dried and replaced and the oven heated at 200°C for about one hour. This will ensure the Cook & Clean panels are working effectively.

Don't use steel wool (Brillo) or any other materials that will scratch the surface. Don't use oven cleaning pads.

Removing the Oven Linings

Some of the lining panels can be removed for cleaning and for cleaning behind. Remove the shelves first.

On some models the right hand fanned oven has a removable oven roof - if fitted slide the roof liner forward and remove.

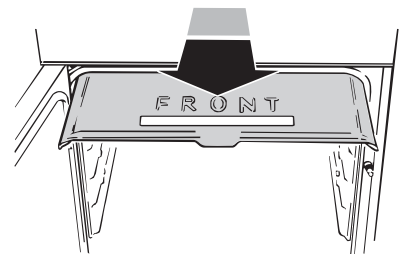

Each side of the oven is fixed with four fixing screws. You don't have to remove the screws to remove the oven linings. Lift each side panel upwards and they will slide off the screws. Then pull them forwards.

Cleaning Table

Hotplate

Part	Finish	Recommended Cleaning Method
Hob Top	Enamel or Stainless Steel	Hot soapy water, soft cloth. Any stubborn stains remove gently with a nylon scourer.
Electric Sealed Hob Plate.	Cast Iron	Remove rust and food debris with a well soaped steel wool pad along the grain. Rinse and allow to dry. Apply Sealed Hot Plate Restorer <i>Easy-Do Products</i> (Electrical Retailers) to restore colour and protect the plates.
Griddle Plate (some models only)	Non-Stick Surface	Allow to cool. Wash in hot soapy water. Do not use abrasive cleaners/scourers. Dishwasher.
Warming Zone (some models only)	Toughened Glass	Hot soapy water, cream cleaner/scourer if necessary.

Outside of cooker

Part	Finish	Recommended Cleaning Method
Door, Door surround and Storage Drawer exterior.	Enamel or paint	Hot soapy water, soft cloth. Any stubborn stains, remove gently with a liquid detergent.
	Stainless Steel	E Cloth (Comet) or Vileda Microfibre Plus All Purpose Cloth <i>Freudenberg Household Products LP</i> (supermarket)
Sides and Plinth	Painted surface	Hot soapy water, soft cloth
Splashback/Rear Grille	Enamel or Stainless Steel	Hot soapy water, soft cloth. Cream cleaner, with care, if necessary.
Control panel	Paint, Enamel or Stainless Steel	Warm soapy water. Do not use abrasive cleaners on lettering.
Control Knobs/Handles	Plastic/ Chrome	Warm soapy water, soft cloth.
Oven Door Glass/Glass Lid	Toughened glass	Hot soapy water, cream cleaner/scourer if necessary.

Oven and Grill

Part	Finish	Recommended Cleaning Method
Sides, floor & roof of oven - NOT COOK & CLEAN OVEN PANELS (see below)	Enamel	Any proprietary oven cleaner that is suitable for enamel. CAUTION: CORROSIVE/CAUSTIC OVEN CLEANERS - FOLLOW MANUFACTURERS INSTRUCTIONS. Do not allow contact with the oven elements.
Cook & Clean Oven Panels (some models only)	Special enamel that partly cleans itself	This surface cleans itself at 200°C and above, or the panels can be removed and washed with hot soapy water and a nylon brush. (see 'The Ovens' in 'Cleaning your cooker')
Oven Shelves, Handyrack, Grill Trivet, Handygrill rack	Chrome	An oven interior cleaner that is suitable for chrome. Soap filled pad. Dishwasher.
Grill Pan/Meat Tin (some models only)	Enamel	Hot soapy water. Soap filled pad (Brillo). Dishwasher.

Cleaners listed are available from Supermarkets or electrical retailers as stated. Cleaner manufacturer in Italics. For enameled surfaces use a cleaner that is approved for use on vitreous enamel. The vitreous enamel association has a list of approved cleaners. Contact them via their website www.ive.org.uk or telephone: 01527 893031.

Regular cleaning is recommended. For easier cleaning, wipe up any spillages immediately.

To help keep your oven clean, cover meat when roasting, with foil or use a roasting bag. Brush vegetables with fat before placing around the meat.

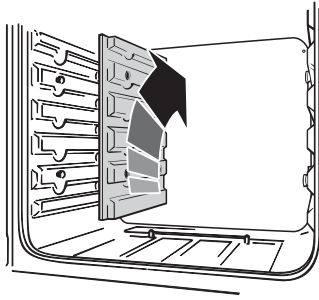

Once the linings are removed, the oven enamel interior can be cleaned.

Moving your cooker

Switch off the electricity supply.

The cooker is heavy, two people may be required to move it. The cooker is fitted with one roller at the front and two at the back. There are also two screw down levelling feet at the front.

The front roller, designed for moving the cooker can be wound down. The levelling tool that controls this roller is in the storage drawer compartment.

Remove the storage drawer (by pulling it right out and lifting it up slightly) and you should see the levelling tool.

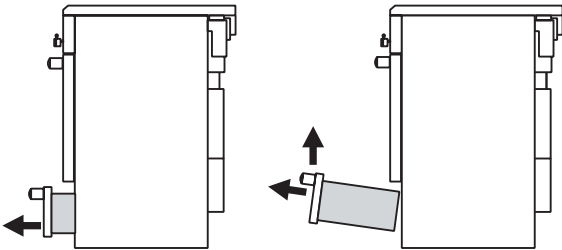

Your installer may not have left the levelling tool in place. If not, locate it as shown. If you cannot find the levelling tool, contact your installer. See the Installation section of these instructions where your installer should have written their contact details.

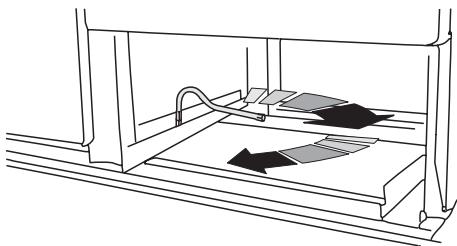

Turn the levelling tool clockwise, two full (180°) turns. It will be stiff. The front of the oven will rise slightly as the roller drops down.

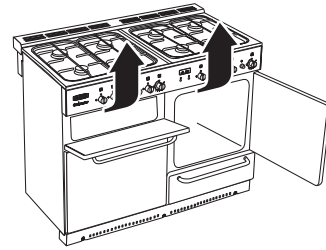

Open the grill door and right hand oven door so that you can get a good grip on the bottom of the fascia panel as you move the oven.

Do not move the oven by pulling the hand rail, door handles or knobs.

Move the oven a bit at a time, checking behind it to make sure the gas hose is not caught. Make sure both electricity and gas cables have sufficient slack to move the cooker forward as you go along.

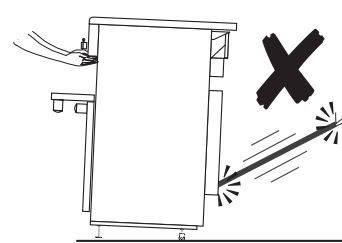

If a stability chain is fitted, release it as you ease the cooker out.

When you replace the cooker, wind it down off the rollers by turning the levelling tool anti-clockwise. This is important. It will stop the cooker moving accidentally, while in use.

When you replace the cooker, wind it down off the rollers by turning the levelling tool anti-clockwise. This is important. It will stop the cooker moving accidentally, while in use.

Troubleshooting

My hobplates are going rusty

The cast iron hobplates will rust if left wet. Don't put wet pans onto the plates. If you spill liquid on a hobplate clean it with a damp cloth, then switch the plate to the lowest setting for a few minutes to dry. Oil the hobplates sparingly about once a month with a few drops of cooking oil then rub over with a cotton cloth. Take care NOT to oil the outer stainless bezel or the red discs on any of the hobplates.

The red spots are coming off my hobplates

The red disc is an identifying mark for high-speed hobplates. It may wear away with use but this will not affect hob performance in any way.

The trims on my hobplates are discolouring

The bright metal hobplate trims may turn a straw colour with use - this is perfectly normal.

Grill not cooking properly

Are you using the pan and trivet supplied with the cooker? Is the pan being used on the runners, not the floor of the compartment? Is the grill tray pushed fully back to stop?

Steam is coming from the oven

During cooking, food naturally produces steam, particularly when cooking foods with high water content (e.g. oven chips). There may be some steam visible at the grille at the rear of the hotplate. This is perfectly normal. Steam can condense to water droplets on the cool outer trim or the oven door. It may be necessary during cooking to wipe away any moisture with a soft cloth. This will also help to prevent soiling and discolouration of the oven exterior by cooking vapours.

Take care when opening the oven door as there may be a momentary puff of steam when the oven door is opened. Stand well back and allow any steam to disperse.

The oven fan is noisy

The note of the oven fan may change as the oven heats up - this is perfectly normal.

The knobs get hot when I use the oven or the grill, can I avoid this?

Yes, this is caused by heat rising from the oven or the grill, and heating them up. Don't leave the oven door open. Make sure that the grill pan is pushed right back to the 'back stop' when grilling.

Food is cooking too slowly, too quickly, or burning

Cooking times may differ from your previous oven. Check that you are using the recommended temperatures and shelf positions. See the 'Oven cooking guide' section of these instructions. The oven control settings and cooking times are intended to be used only as a guide. Individual tastes may require the temperature to be altered either way, to get the results you want. Try cooking at a higher temperature setting. Is the oven roof in? Is it the right way round? Is it pushed back fully back? Is it resting on the liners?

The oven is not cooking evenly

Do not use a tin or baking tray larger than 340mm x 305mm.

If you are cooking a large item, be prepared to turn it round during cooking.

If two shelves are used, check that space has been left for the heat to circulate. When the baking tray is put into the oven, make sure it is placed centrally on the shelf.

Check that the door seal is not damaged and that the door catch adjusted so that the door is held firmly against the seal.

NB the seal is intended to have a gap at the bottom of the door

A dish of water when placed on the shelf should be the same depth all over. (For example, if it is deeper at the back, then the back of the cooker should be raised up or the front lowered). If the cooker is not level arrange for your supplier to level it for you.

Oven not coming on when turned on manually

Is the power on? Is the clock illuminated? If not there may be something wrong with the power supply. Is the cooker supply on at the isolator switch? Is the clock flashing 0.00? If so set it to the correct time of day. Has the Timer been set to AUTO by mistake. If AUTO is showing on the clock display, press the 'cook period' button and reduce any set cooking time showing to 0.00, with the (+) and (-) buttons. Press the  button twice.

Is the key symbol (ⓘ) showing in the display? See the Clock section of the instructions for more information on the key lock feature of the clock.

Oven not coming on when automatic cooking

Timer set correctly but oven knob left OFF by mistake?

Is the key symbol (ⓘ) showing in the display? See the Clock section of the instructions for more information on the key lock feature of the clock.

Oven temperature getting hotter as the cooker gets older

If turning the knob down has not worked or only worked for a short time then you may need a new thermostat. This should be fitted by a service person.

The oven light is not working

The bulb has probably blown. You can buy a replacement bulb (which is not covered under the guarantee) from a good electrical shop. Ask for an Edison screw fitting 15w 230v lamp, FOR OVENS. It must be a special bulb, heat resistant to 300 °C.

Open the oven door and remove the Handyrack (if fitted) and oven shelves.

Turn off the power supply.

Unscrew the bulb cover by turning anticlockwise. Unscrew the old bulb. Screw in the new bulb, screw back the bulb cover. Turn on the electricity supply and check that the bulb now lights.

Current Operated Earth Leakage Breakers

Where the cooker installation is protected by a 30 milliamp sensitivity residual current device (RCD), the combined use of your cooker and other domestic appliances may occasionally cause nuisance tripping. In these instances the cooker circuit may need to be protected by fitting 100mA device. This work should be carried out by a qualified electrician.

If there is an installation problem and I don't get my original installer to come back to fix it who pays?

You do. Service organisations will charge for their call outs if they are correcting work carried out by your original installer. It's in your interest to track down your original installer.

What cleaning materials are recommended for the cooker?

See the 'Cleaning' section for recommended cleaning materials. We do not recommend Mr. Muscle, as it contains chemicals that may damage the surfaces of your cooker.



General Safety Instructions

The cooker must be installed by a qualified electrician in accordance with the installation instructions. It should be serviced by a qualified service engineer and only approved spare parts used. Have the installer show you the location of the cooker control switch. Mark it for easy reference. Always allow the cooker to cool and then switch off at the mains and before cleaning or carrying out any maintenance work, unless specified otherwise in this guide.

All parts of the cooker become hot with use and will retain heat even after you have stopped cooking.

Take care when touching the hob especially the hob plates. The hob plates will retain heat after the controls have been turned off. To minimize the possibility of burns, always be certain that the hob controls are in the OFF position and that the entire surface is cool before attempting to clean the hob.

This appliance is designed for domestic cooking only. Use for any other purpose could invalidate any warranty or liability claim.

The cooker should be serviced by an Authorised Person and only approved spare parts used. Have the installer show you the location of the cooker control switch. Mark it for easy reference. Always allow the cooker to cool and then switch off at the mains and before cleaning or carrying out any maintenance work, unless specified otherwise in this guide.

All parts of the cooker become hot with use and will retain heat even after you have stopped cooking.

Take care when touching cooker, to minimize the possibility of burns, always be certain that the controls are in the OFF position and that it is cool before attempting to clean the cooker. Avoid touching heating elements.

Use dry oven gloves when applicable - using damp gloves might result in steam burns when you touch a hot surface. Never operate the cooker with wet hands.

Do not use a towel or other bulky cloth in place of a glove. They might catch fire if they touch a hot surface.

Clean with caution. If a wet sponge or cloth is used to wipe spills on a hot surface, be careful to avoid steam burns. Some cleansers can produce noxious fumes if applied to a hot surface.

Do not use unstable saucepans and position the handles away from the edge of the hotplate.

The appliance is not intended for unsupervised use by young children or infirm persons. Babies, toddlers and young children should not be allowed near the cooker at any time. They should never be allowed to sit or stand on any part of the appliance. Teach them not to play with controls or any other part of the cooker.

Never store anything of interest to children in cabinets above a cooker - children climbing on the cooker to reach them could be seriously injured.

Clean only parts listed in this guide.

In the interests of hygiene and safety the cooker should be kept clean at all times as a build up in fats and other food stuff could result in a fire.

Always keep combustible wall coverings or curtains etc. a safe distance away from your cooker. For more detail see the Installation section of these instructions.

Do not store or use flammable liquids or materials in the vicinity of this appliance. This includes some cleaning solvents and chemicals used in dry cleaning.

Do not use water on grease fires. Never pick up a flaming pan. Turn the controls off. Smother a flaming pan on a surface unit by covering the pan completely with a well fitting lid or baking tray. If available use a multipurpose dry chemical or foam-type fire extinguisher.

Never leave the hotplate unattended at high heat settings. Pans boiling over can cause smoking and greasy spills may catch on fire.

Never wear loose-fitting or hanging clothes while using the appliance. Be careful when reaching for items stored in cabinets over the hotplate. Flammable material could be ignited if brought in contact with a hot surface unit and may cause severe burns.

Take great care when heating fats and oils, as they will ignite if they get too hot.

Use a deep fat thermometer whenever possible to prevent overheating fat beyond the smoking point.

Never leave a chip pan unattended. Always heat fat slowly, and watch as it heats. Deep fry pans should be only one third full of fat. Filling the pan too full of fat can cause spill over when food is added. If you use a combination of oils or fats in frying, stir them together before heating, or as the fats melt.

Foods for frying should be as dry as possible. Frost on frozen foods or moisture on fresh foods can cause hot fat to bubble up and over the sides of the pan. Carefully watch for spills or overheating of foods when frying at high or medium high temperatures. Never try to move a pan of hot fat, especially a deep fat fryer. Wait until the fat is cool.

When the grill is on, do not use the top of the flue (the slot along the back of the cooker) for warming plates, dishes, drying tea towels or softening butter.

When using an electrical appliance near the hotplate, be sure that the cord of the appliance does not come into contact with the hobplate.

Take care that no water seeps into the appliance

Only certain types of glass, glass-ceramic, earthenware or other glazed containers are suitable for hotplate cooking; others may break because of the sudden change in temperature.

Do not allow anyone to climb, stand or hang on any part of the cooker.

Do not use aluminium foil to cover shelves, linings or the oven roof.

Make sure that your kitchen is well ventilated at all times. Use extractor fans or hoods when fitted.

Never heat unopened food containers. Pressure build up may make container burst and cause injury.

The cooker is designed for cooking foods only and must not be used for any other purpose.

The oven should NOT be used for heating the kitchen, not only does this waste fuel but the control knobs may become overheated.

When the oven is on DO NOT leave the oven door open for longer than necessary.

The specification of this cooker should not be altered.

This appliance is heavy, take care when moving it.

When the cooker is not in use ensure that the control knobs are in the off position.

Installation

Dear Installer

Before you start your installation, please complete the details BELOW.

If your customer has a problem relating to your installation they will be able to contact you easily.

Thank you

Installer's Name

Installer's Company

Installer's Telephone number

Regulations

This appliance must be installed by a qualified electrician to comply with the relevant regulations and also the local electricity supply company requirements.

You will need the following equipment to complete the cooker installation satisfactorily

- ▶ **Multimeter (for electrical checks)**
- ▶ **Steel tape measure**
- ▶ **Cross head screwdriver**
- ▶ **Spirit level**
- ▶ **Cooker levelling tool (provided in pack)**

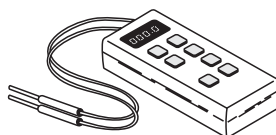
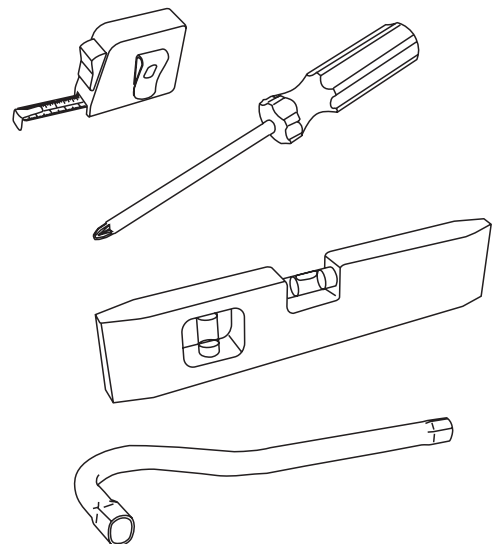

Positioning the Cooker

The diagrams below show the minimum recommended distance from the cooker to nearby surfaces.

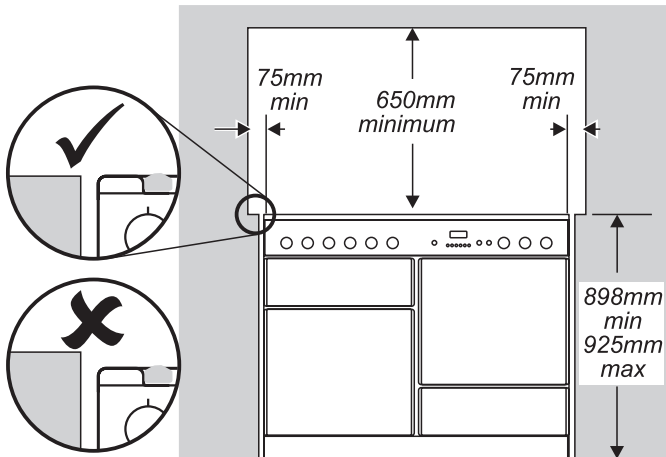

The hob surround should be level with, or above, any adjacent work surface. Above hotplate level a gap of 75mm should be left between each side of the cooker and any adjacent vertical surface.

For non-combustible surfaces (such as unpainted metal or ceramic tiles) this can be reduced to 25mm.

A minimum space of 650mm is required between the top of the hob and a horizontal combustible surface.

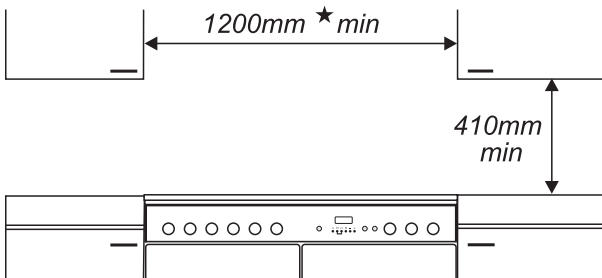

*Any cooker hood should be installed in accordance with the hood manufacturer's instructions.

Surfaces of furniture and walls at the sides and rear of the appliance should be heat, splash and steam resistant. Certain types of vinyl or laminate kitchen furniture are particularly prone to heat damage and discolouration. We cannot accept responsibility for damage caused by normal use of the cooker to any material that de-laminates or discolours at temperatures less than 65°C above room temperature.

For safety reasons curtains must not be fitted immediately behind the cooker.

We recommend a gap of 1110mm between units to allow for moving the cooker. If a flush fit is required, fit the cooker up to the unit at one side then fit the unit the other side. Do not box the cooker in; it must still be possible to move the cooker in and out for cleaning and servicing. The cooker should not be placed on a base.

Checking the parts

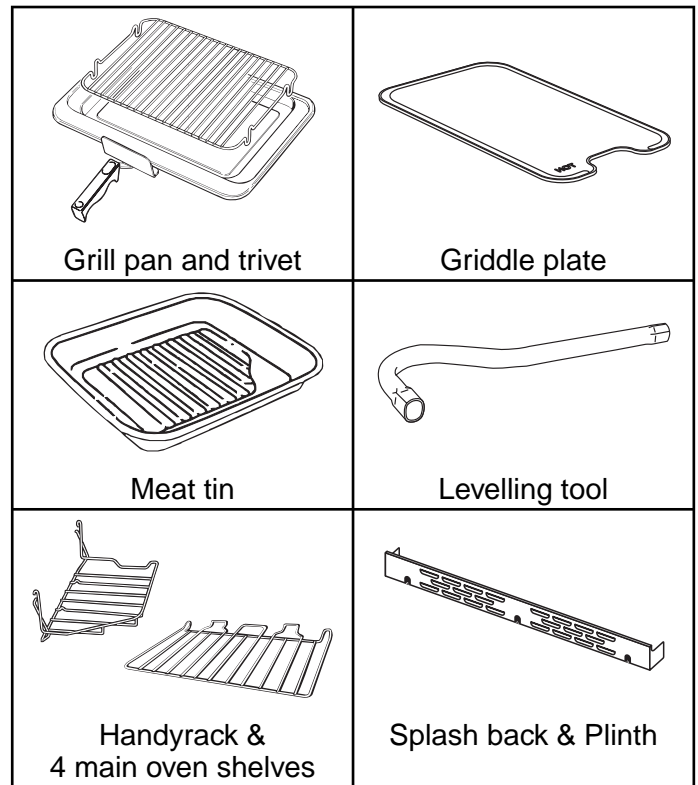

A clearance of 130mm is required if the cooker is near a corner of the kitchen to allow the oven doors to open.

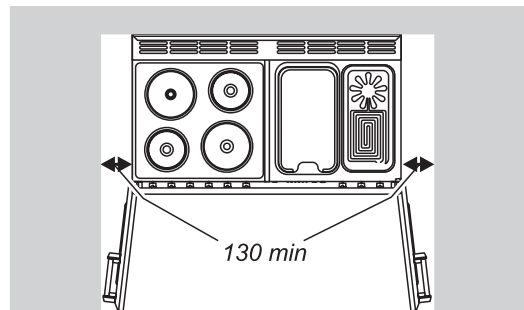

Unpacking the Cooker

Do not take any packaging off the cooker until it is directly in front of the place it is to be installed (unless it will not fit through a door in its outer packaging).

See the loose unpacking sheet.

Moving the Cooker

The cooker is very heavy. Take great care.

We recommend two people manoeuvre the cooker.

Ensure that the floor covering is firmly fixed, or removed to prevent it being disturbed when moving the cooker around. You will need the levelling tool.

Pull the warmer drawer out to its furthest point.

Lift it up and out.

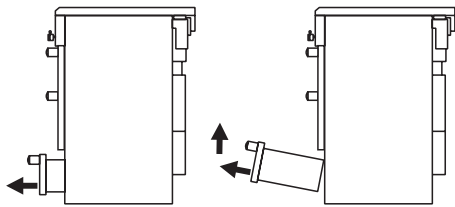

Fit the levelling tool on the rectangular adjuster as shown below.

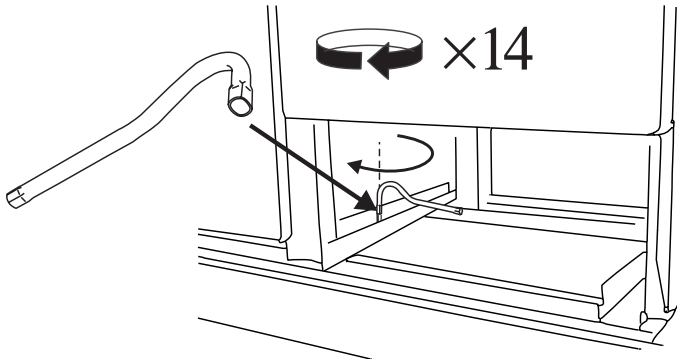

LOWER THE FRONT ROLLER by doing 14 complete (360°) turns clockwise. (This means turning and removing the levelling tool 56 times).

Now LOWER THE TWO REAR ROLLERS.

First fit the levelling tool on the hexagonal adjusting nut as shown below.

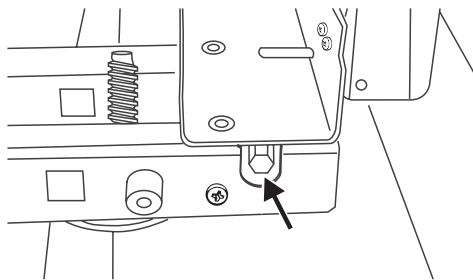

Make 10 complete (360°) turns clockwise. (This means turning and removing the levelling tool 20 times).

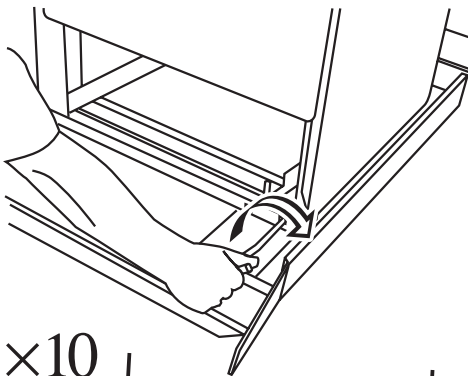

Make sure you lower BOTH REAR ROLLERS. There are two adjusting nuts, one for each roller, at both the front bottom corners of the cooker.

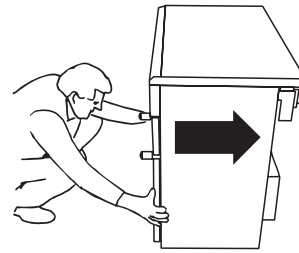

Carefully push the cooker backwards close to its final position leaving just enough space to get behind it. Take care not to damage the power cable.

Do not use the door handles or control knobs to manoeuvre the cooker. Remove the pack base tray.

Levelling

You are recommended to use a spirit level on a shelf in one of the ovens to check for level.

Place the cooker in its intended position taking care not to twist it within the gap between the kitchen units as damage may occur to the cooker or the units.

The rollers can be adjusted to level the cooker. To adjust the height of the rear of the cooker use the levelling tool supplied to turn the adjusting nuts at the front bottom corners of the cooker.

Adjust the height of the front roller to level the cooker. Turn clockwise to raise the cooker and anticlockwise to lower.

When you are satisfied with the height and level raise the front of the cooker by one turn of the front roller adjuster. Screw down the front feet to meet the floor. Screw the front roller adjuster anticlockwise to raise the front roller so that the front of the cooker is supported on the feet, **not** the front roller, to prevent accidental movement of the cooker.

Leave the levelling tool on the adjuster with the handle of the tool facing the rear of the cooker, so that the customer can use it if they wish to move the cooker.

Replace the drawer by locating on side runners and push in.

Electrical Connection

This appliance must be installed by a qualified electrician to comply with the relevant Institute of Electrical Engineers (I.E.E.) regulations and also the local electricity supply company requirements.

WARNING: THIS APPLIANCE MUST BE EARTHED

Note

The cooker must be connected to the correct electrical supply as stated on the voltage label on the cooker, through a suitable cooker control unit incorporating a double pole switch having a contact separation of at least 3mm in all poles. This cooker must not be connected to an ordinary domestic power point.

The cable size used should be between 6mm² and 10mm², twin and earth.

Access to the mains terminal is gained by removing the electrical terminal cover box on the back panel.

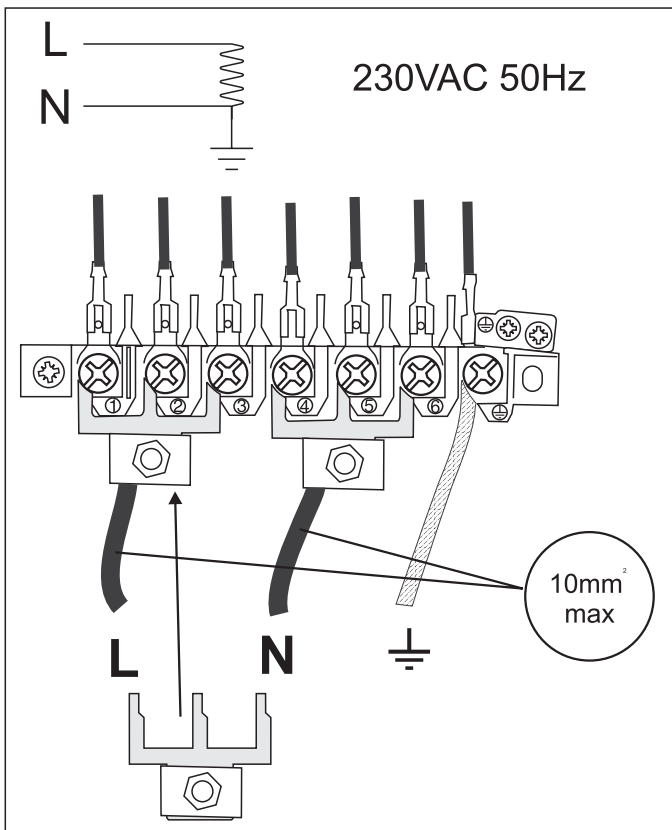

This shows the single-phase connection. the mains cable to the correct terminals for your electrical supply type (see fig.). Check that the links are correctly fitted and that the terminal screws are tight. Secure the mains cable using the cable clamp. These appliances are of type X with regard to protection against over heating of the surrounding surfaces.

Current Operated Earth Leakage Breakers

Where the installation is protected by a 30 milliamp sensitivity residual current device (RCD), the combined use of your cooker and other domestic appliances may occasionally cause nuisance tripping. In these instances the cooker circuit may need to be protected by fitting 100mA device. This work should be carried out by a qualified electrician

Fitting the plinth

Loosen the 3 screws along the front bottom edge of the cooker. Hook the central keyhole over the central screw. Twist and fit each end keyhole over their respective screws. Tighten the fixing screws.

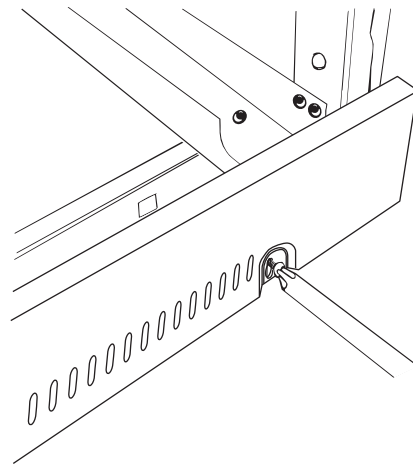

Oven Light

Press the oven light switch and check that the light is working.

NB The oven light bulb is not included in the guarantee

Hobplate

Turn on each plate in turn and check that it heats up.

Grill

Open the grill compartment door. Turn on the grill control and check that the grill heats up.

Oven check

The clock must be set to the time of day before the ovens will work.

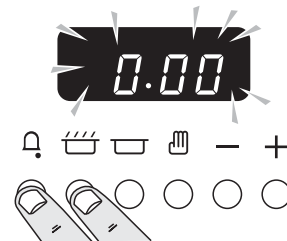

Press and hold as above. At the same time, press - or + until the correct time shows. Don't forget it's a 24 hour clock. If you make a mistake or press the wrong button, turn off the power supply for a minute or two and start again. Turn on the oven and check that the oven fan starts to turn and that the oven starts to heat up. Turn off the oven.

Customer care

Please complete your details in this Guide, inform the user how to operate the cooker and hand over the Instructions.

Thank you.

Circuit Diagram

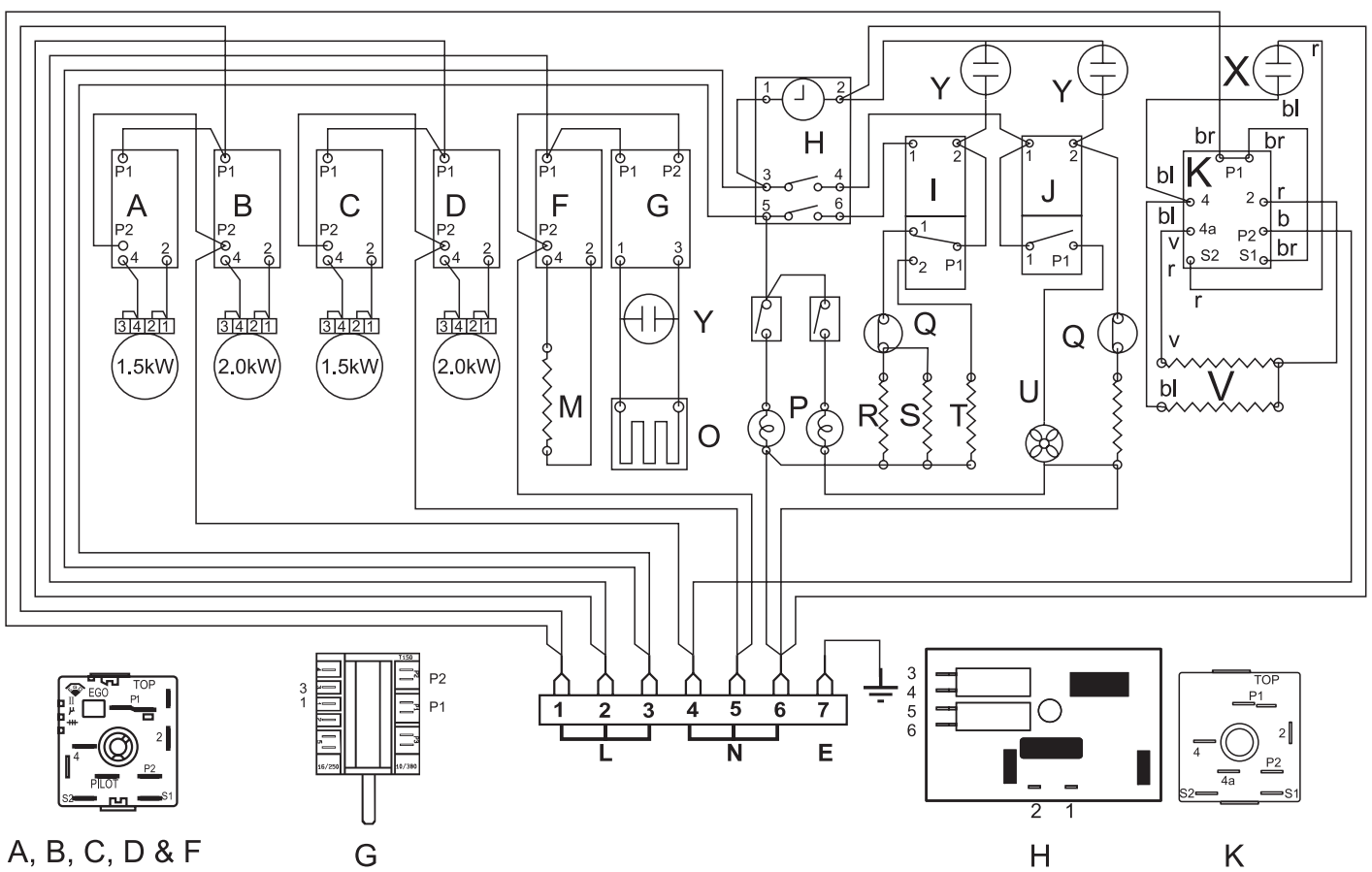

Connection shown in circuit diagram is for single phase. Ratings are for 230V 50Hz

- A Left hand front hobplate energy regulator
- B Left hand rear hobplate energy regulator
- C Right hand rear hobplate energy regulator
- D Right hand front hobplate energy regulator
- E Earth
- F Griddle energy regulator
- G Warmer Switch
- H Clock
- I Left hand oven thermostat
- J Right hand oven thermostat
- K Grill energy regulator
- L Live
- M Griddle Element 1.5kW

- N Neutral
- O Warmer 147W
- P Oven light bulbs
- Q Cutouts
- R Base element 1.0kW
- S Top element 1.2kW
- T Browning element 1.15kW
- U Right hand oven fan
- V Fan oven element 2.5kW
- W Right hand grill element 1.15kW
- X Left hand grill element 1.15kW
- Y Neon

Technical Data

INSTALLER: Please leave these instructions with the User.

DATA BADGE LOCATION : LOWER RIGHT HAND COOKER UPRIGHT (Remove storage drawer)

Electric	220 - 240V 50Hz
-----------------	------------------------

Dimensions

Overall height	minimum 893mm	maximum 920mm
Overall width	1100mm See 'Positioning of Cooker'	
Overall depth	648mm	
Space for fixing	See 'Positioning of Cooker'	
Minimum space above hotplate	650mm	

Connections

Electric
220 - 240V 50Hz

Ratings

Hob	Left Hand	Right Hand
Front	1.5kW	2.0kW
Rear	2.0kW	1.5kW

Ovens	Conventional		Forced air convection
	Oven	Browning Element	Oven
	2.2kW	1.15kW	2.5kW
Energy efficiency class on a scale of A (more efficient) to G (less efficient)	A		A
Energy consumption based on standard load	0.99kWh		0.85kWh
Usable volume (litres)	67		67
Size	Large		Large
Time to cook standard load	40 minutes		38 minutes
Surface area of the grid	1400cm ²		1400cm ²

Grill	2.3kW
Griddle	1.5kW
Warmer	160W

Maximum total electrical load at 230V 15.9kW (approximate total including oven lights, oven fan etc.)

RANGEmaster

Clarence Street, Royal Leamington Spa,
Warwickshire, CV31 2AD, England.
Tel: +44 (0) 1926 457400 Fax: +44 (0) 1926 450526
E-mail: consumers@rangemaster.co.uk
www.rangemaster.co.uk

AGA FOODSERVICE GROUP

